

Please Approve this Drawing

|           |  |
|-----------|--|
| Date      |  |
| Signature |  |

| NO. | Part Name | Q'TY | Material | Plated surface                |
|-----|-----------|------|----------|-------------------------------|
| 1   | Plunger   | 1    | Brass    | Au 3u" Min. Over 50u" Min. Ni |
| 2   | Barrel    | 1    | Brass    | AU 3U" MIN OVER 50 U" Min. NI |
| 3   | Spring    | 1    | SUS      | AU 1U" MIN OVER NI            |

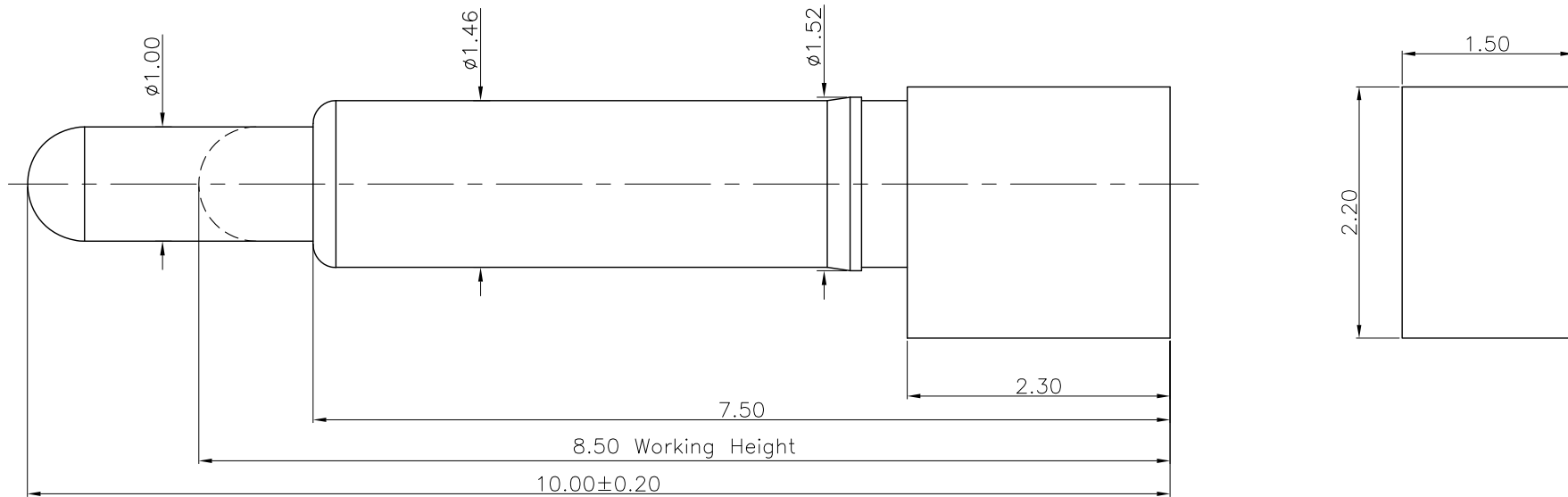

NOTES:

- Electrical
  - .Rated Current & Voltage : DC 12 V ; 1.0A
  - .Contact Resistance:50 mohm maximum at Working Height(Quiescence)
- Mechanical
  - .Full store: 2.00 mm
  - .Spring Force : 100gf±20gf at Working Store
  - .Durability:20,000 cycles(minimum)
- Environmental
  - .Operating Temperature: -40°C~+70°C
  - .Humidity Range: 10%RH~90%RH
  - .Salt Spray: 48 Hours
- When the current is greater than 1A then need to increase the time delay circuit(3 second)
- To avoid arcing issue, The adaptor start to power supply after connector mated fully.
- To ensure the best usage,please operate it based on the working height.
- RoHS&HF compliant product.

|          |        |             |                 |      |     |             |           |  |  |  |
|----------|--------|-------------|-----------------|------|-----|-------------|-----------|--|--|--|
| DRAWN    | CDH    | DATE        | 2020.11.19      |      |     | 东莞市双盟电子有限公司 |           |  |  |  |
| CHECKED  |        | SCALE       | 10:1            | VER. | B.0 |             |           |  |  |  |
| APPROVED |        | TITLE       | pogo pin        |      |     | Ang:        | Dim:      |  |  |  |
| PROJECT  |        | DRAWING NO. | PPM.01-512-0302 |      |     | 0 ±1°       | 0 ±0.15   |  |  |  |
| SHEET    | 1 of 1 | UNIT        | mm              |      |     | .0 ±0.5°    | .0 ±0.10  |  |  |  |
|          |        |             |                 |      |     | .00 ±0.25°  | .00 ±0.05 |  |  |  |

|           |                 |              |          |
|-----------|-----------------|--------------|----------|
| VER. (版本) | DESCRIPTION(描述) | ECN NO.(变更号) | DATE(日期) |
|-----------|-----------------|--------------|----------|