

Note:

...Materials:

Plunger: **Brass** C3604 ,plating 1U" Min Au over 60~100U" Ni min;

Barrel: **Brass** C3604 ,plating 1U" Min Au over 60~100U" Ni min;

Spring: SUS304 .

...Mechanical:

Spring force:120g±20g, at 6.35mm working height.

Full storke:6.15mm.

Mechanical life:10000 cycle Min.

...Electrical:

Voltage:12 V.

Current:1.0 A .

Contact resistance:50mΩ Max at working height.

...ROHS or REACH compliant product.

...Salt spray test:48 H.

...& Key inspection dimension .

| REV | Description | ECN NO | DATE       |
|-----|-------------|--------|------------|
| A0  | —————       | —————  | 2018/11/19 |
| A1  | 更改弹力        |        | 2019/06/05 |

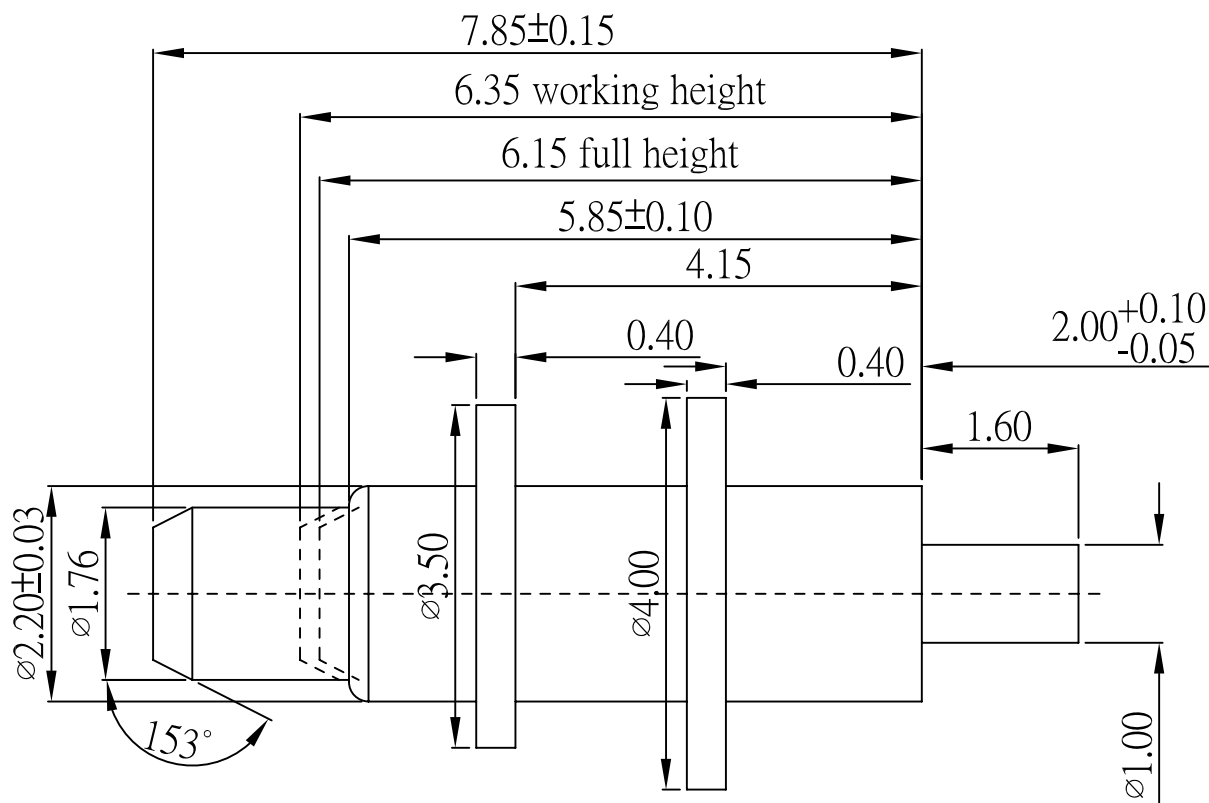

|             |                   |        |           |        |           |  |
|-------------|-------------------|--------|-----------|--------|-----------|--|
| 东莞市双盟电子有限公司 | Nuits:            | mm     | Tolerance |        | Drawn:    |  |
|             | Scale:            | 1:1    | 0~6       | ±0.05  | Checked:  |  |
|             | Size:             | A4     | 7~50      | ±0.10  | Approved: |  |
| Title:      | Pogo pin          | Sheet: | 1/1       | >50    | ±0.20     | Other tolerance unless otherwise noted<br>(其他公差除非另有说明) |
| Part NO:    | PPM. 01-100-0101A | Porj:  |           | Angle: | ±2°       |  |

|     |           |         |               |     |
|-----|-----------|---------|---------------|-----|
| 3   | G1008A-01 | Barrel  | —————         | 1   |
| 2   | T1008A-01 | Plunger | —————         | 1   |
| 1   | H1008A-00 | Spring  | —————         | 1   |
| NO. | P/N       | Name    | Specification | Qty |