

Please Approve this Drawing	
Date	
Signature	

NO.	Part Name	Q'TY	Material	Plated surface
1	Plunger	1	无铅铜 HBI59	AU 3 U" MIN OVER 50 U" MIN NI
2	Barrel	1	无铅铜 HBI59	AU 3 U" MIN OVER 50 U" MIN NI
3	Spring	1	SUS304	/
4	Plunger	1	无铅铜 HBI59	AU 3 U" MIN OVER 50 U" MIN NI

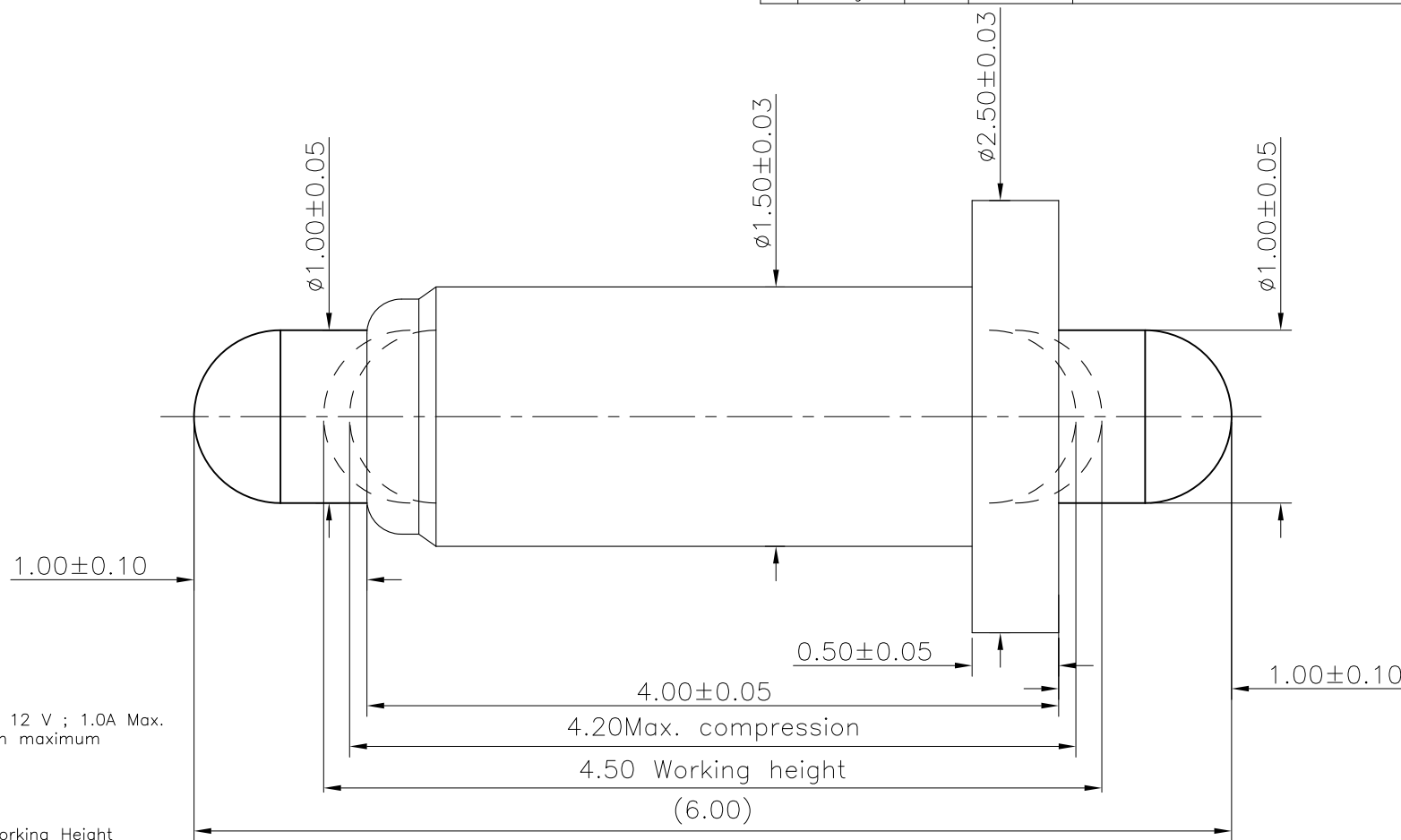

NOTES:

- Electrical
 - .Rated Current & Voltage : DC 12 V ; 1.0A Max.
 - .Contact Resistance: 100 mohm maximum at Working Height(Quiescence)
- Mechanical
 - .Full store: 1.80 mm
 - .Working Store: 1.50 mm
 - .Spring Force: 90gf±20gf at Working Height
 - .Durability:10,000 cycles(minimum)
- Environmental
 - .Operating Temperature: -40°C~+85°C
 - .Humidity Range: 10%RH~90%RH
 - .Salt Spray: 48 Hours
- When the current is greater than 1A then need to increase the time delay circuit(3 second)
- To avoid arcing issue, The adaptor start to power supply after connector mated fully.
- To ensure the best usage, please operate it based on the working height.
- .RoHS&HF compliant product.

DRAWN	CDH	DATE	2022.10.26			东莞市双盟电子有限公司	
CHECKED		SCALE	10:1	VER.	A.0		
APPROVED		TITLE	PoGo Pin			Ang:	Dim:
PROJECT		DRAWING NO.	PPM.01-5318-0302			0 ±1°	0 ±0.15
SHEET	1 of 1	UNIT	mm			.0 ±0.5°	.0 ±0.10
					.00 ±0.25°	.00 ±0.05	

VER.	DESCRIPTION	ECN NO.	DATE
------	-------------	---------	------