

Please Approve this Drawing

Date

Signature

NO.	Part Name	Q'TY	Material	Plated surface
1	Plunger	1	HBi59	Au 30u" Min. OVER 100 U" NI
2	Barrel	1	HBi59	Au 16u" Min. OVER 100 U" NI
3	Spring	1	SUS304	/
4				

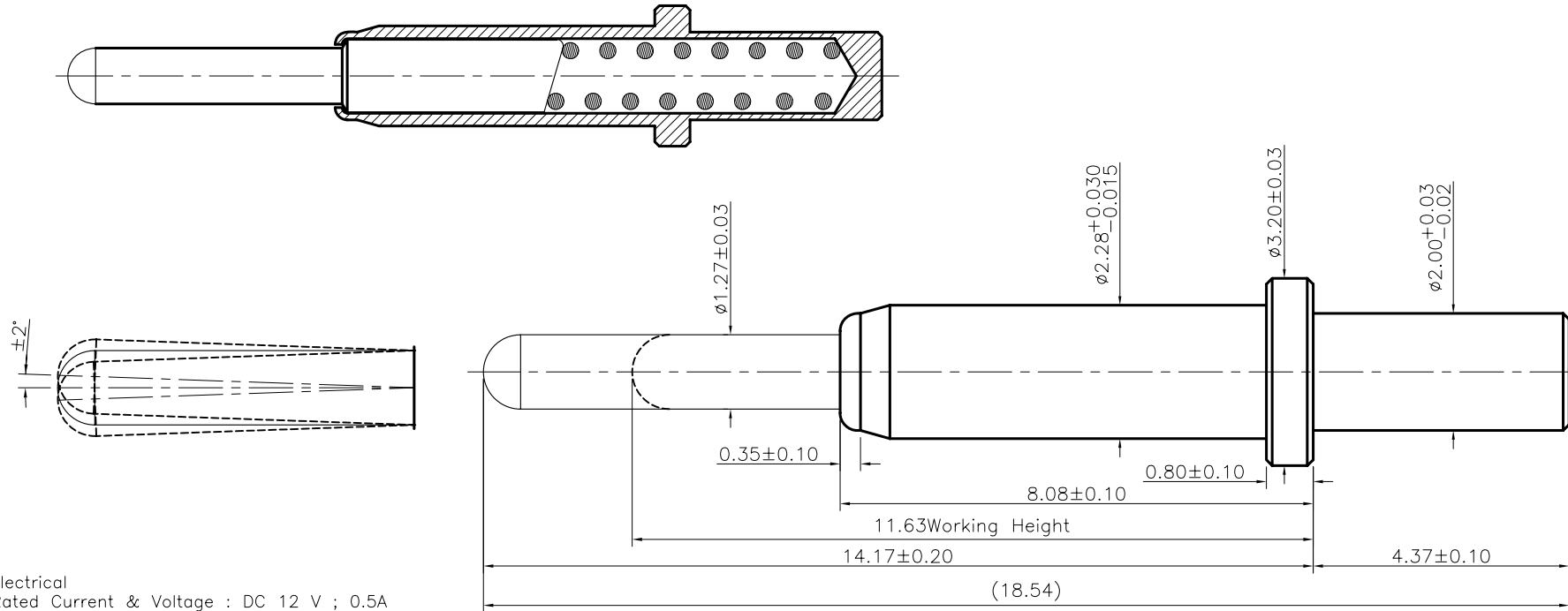

NOTES:

- Electrical
 - .Rated Current & Voltage : DC 12 V ; 0.5A
 - .Contact Resistance: 45 mohm maximum at Working Height(Quiescence)
- Mechanical
 - .Full Stroke: 3.81mm
 - .Finit : 0.40N
 - .Spring Force : 0.50N at 12.89mm
 - .Spring Force : 0.60 ± 0.17 N at 11.63mm Working Height
 - .Spring Force : 0.70N at 10.36mm
 - .Durability:10,000 cycles(minimum)
- Environmental
 - .Operating Temperature: $-30^{\circ}\text{C} \sim +85^{\circ}\text{C}$
 - .Humidity Range: 10%RH~90%RH
 - .Salt Spray: 48 Hours
- When the current is greater than 1A then need to increase the time delay circuit(3 second)
- To avoid arcing issue, The adaptor start to power supply after connector mated fully.
- To ensure the best usage, please operate it based on the working height.
- .RoHs&HF compliant product.

VER.	DESCRIPTION	ECN NO.	DATE

DRAWN	lys	DATE	2021.01.14		东莞市双盟电子有限公司	
CHECKED		SCALE	10:1	VER. B.0		
APPROVED		TITLE	pogo pin		Ang:	Dim:
PROJECT		DRAWING NO.	PPM.01-705-3002		0 ±1°	0 ±0.15
SHEET	1 of 1	UNIT	mm		.0 ±0.5°	.0 ±0.10
					.00 ±0.25°	.00 ±0.05