

Please Approve this Drawing	
Date	
Signature	

NO.	Part Name	Q'TY	Material	Plated surface
1	Plunger	1	无铅铜	Au 3u" Min. OVER 50~120 U" NI
2	Barrel	1	无铅铜	Au 3u" Min. OVER 50~120 U" NI
3	Spring	1	SUS 304	Au 1u" Min. OVER NI
4				

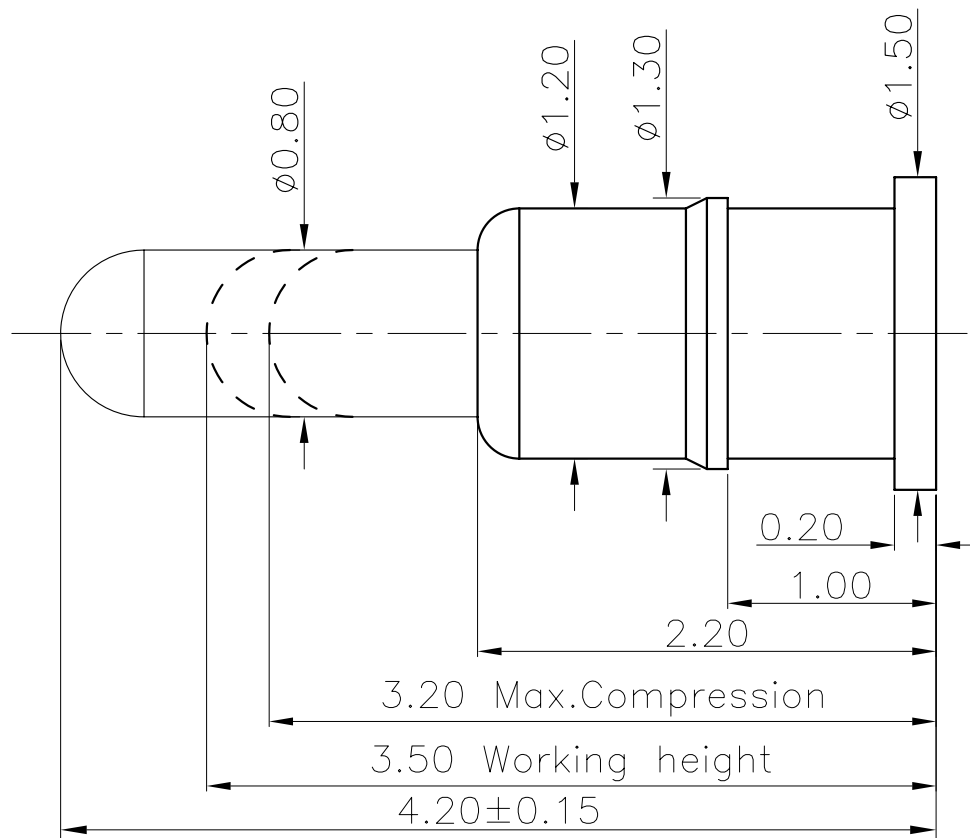

NOTES:

- Electrical
 - .Rated Current & Voltage : DC 12 V ; 1.0A
 - .Contact Resistance: 100 mohm maximum at Working Height(Quiescence)
- Mechanical
 - .Full store: 1.00 mm
 - .Spring Force : 60g±20%g at Working Height
 - .Durability:10,000 cycles(minimum)
- Environmental
 - .Operating Temperature: -40°C~+85°C
 - .Humidity Range: 10%RH~90%RH
 - .Salt Spray: 48 Hours
- When the current is greater than 1A then need to increase the time delay circuit(3 second)
- To avoid arcing issue, The adaptor start to power supply after connector mated fully.
- To ensure the best usage,please operate it based on the working height.
- .RoHs&HF compliant product.

VER.	DESCRIPTION	ECN NO.	DATE

DRAWN	lys	DATE	2021.05.29			东莞市双盟电子有限公司	
CHECKED		SCALE	10:1	VER.	B.0		
APPROVED		TITLE	pogo pin			Ang:	Dim:
PROJECT		DRAWING NO.	PPM.01-350-0302			0 ±1°	0 ±0.15
SHEET	1 of 1	UNIT	mm			.0 ±0.5°	.0 ±0.10
						.00 ±0.25°	.00 ±0.05