

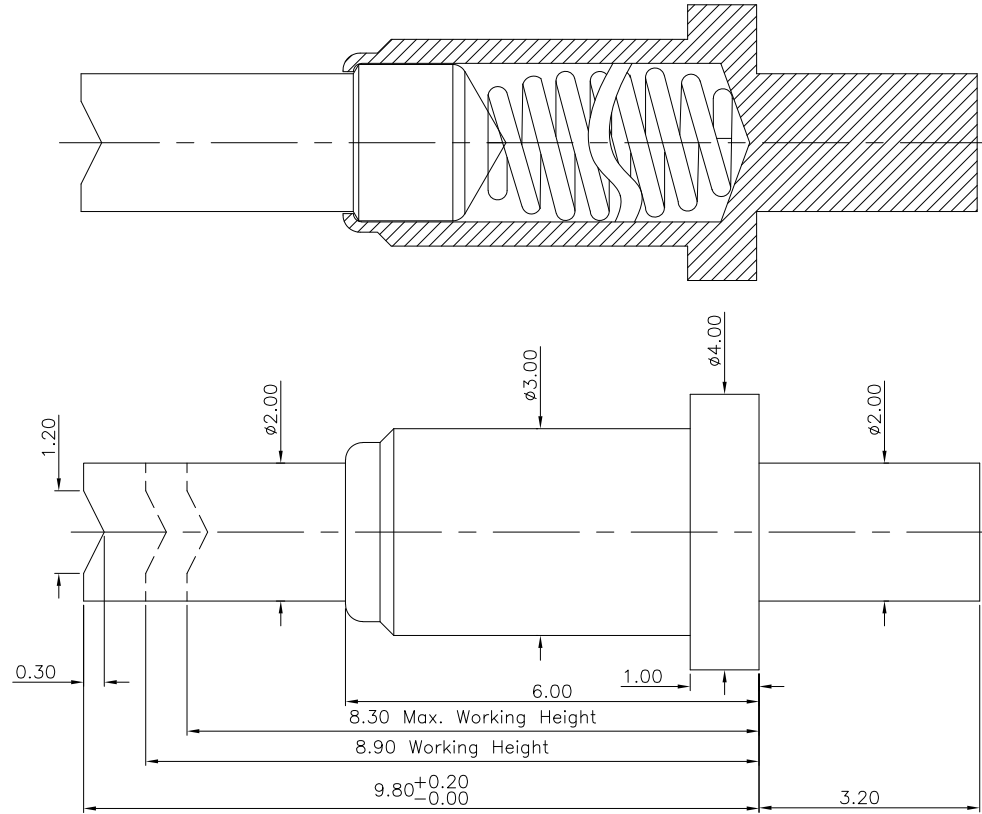

Please Approve this Drawing	
Date	
Signature	

NO.	Part Name	Q'TY	Material	Plated surface
1	Plunger	1	IBi59	Au 10u" Min. OVER 50~120 U" NI
2	Barrel	1	IBi59	Au 10u" Min. OVER 50~120 U" NI
3	Spring	1	SUS 304	Au 1u" Min. OVER NI



NOTES:

- Electrical
  - .Rated Current & Voltage : DC 9 V ; 1.5A
  - .Contact Resistance: 30 mohm maximum at Working Height(Quiescence)
- Mechanical
  - .Full store: 1.50 mm
  - .Spring Force : 150g~200g at Working Height
  - .Durability:10,000 cycles(minimum)
- Environmental
  - .Operating Temperature: -30°C~+85°C
  - .Humidity Range: 10%RH~90%RH
  - .Salt Spray: 96 Hours
- When the current is greater than 1A then need to increase the time delay circuit(3 second)
- To avoid arcing issue, The adaptor start to power supply after connector mated fully.
- To ensure the best usage,please operate it based on the working height.
- .RoHs&HF compliant product.

DRAWN	lys	DATE	2022.04.07			 东莞市双盟电子有限公司
CHECKED		SCALE	10:1	VER.	C.0	
APPROVED		TITLE	pogo pin			Ang:
PROJECT		MPN NO.	PPM.01-236-1002C			0 ±1°
SHEET	1 of 1	UNIT	mm			.0 ±0.5°
						.00 ±0.25°
						Dim: 0 ±0.15
						.0 ±0.10
						.00 ±0.05

VER.	DESCRIPTION	ECN NO.	DATE