

Please Approve this Drawing	
Date	
Signature	

NO.	Part Name	Q'TY	Material	Plated surface
1	Plunger	1	Brass	AU 1 U" MIN OVER 50~120 U" NI
2	Barrel	1	Brass	AU 1 U" MIN OVER 50~120 U" NI
3	Spring	1	SUS	/
4				

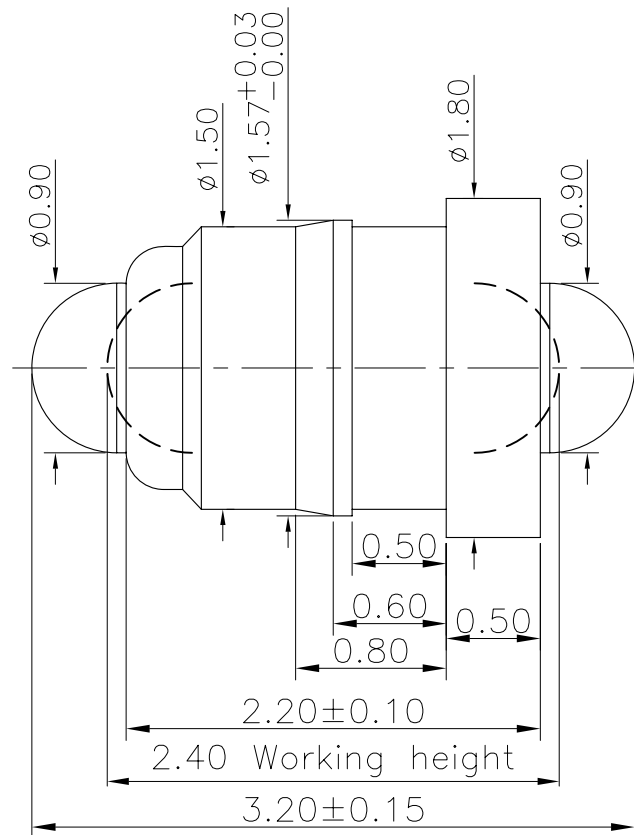

NOTES:

- Electrical
  - .Rated Current & Voltage : DC 12 V ; 1.0A Max.
  - .Contact Resistance: 50 mohm maximum at Working Height(Quiescence)
- Mechanical
  - .Full store: 0.90 mm
  - .Working Store: 0.80 mm
  - .Spring Force: 60gf $\pm$ 15gf at Working Height
  - .Durability:10,000 cycles(minimum)
- Environmental
  - .Operating Temperature:  $-30^{\circ}\text{C} \sim +85^{\circ}\text{C}$
  - .Humidity Range: 10%RH $\sim$ 90%RH
  - .Salt Spray: 48 Hours
- When the current is greater than 1A then need to increase the time delay circuit(3 second)
- To avoid arcing issue, The adaptor start to power supply after connector mated fully.
- To ensure the best usage,please operate it based on the working height.
- .RoHs&HF compliant product.

DRAWN	lys	DATE	2020.09.07			东莞市双盟电子有限公司				
CHECKED		SCALE	10:1	VER.	B.0					
APPROVED		TITLE	pogo pin			Ang:	Dim:			
PROJECT		DRAWING NO.	PPM.01-268-0102			0 $\pm$ 1°	0 $\pm$ 0.15			
SHEET	1 of 1	UNIT	mm			.0 $\pm$ 0.5°	.0 $\pm$ 0.10			
						.00 $\pm$ 0.25°	.00 $\pm$ 0.05			

VER.	DESCRIPTION	ECN NO.	DATE