

Please Approve this Drawing	
Date	
Signature	

NO.	Part Name	Q'TY	Material	Plated surface
1	Plunger	1	HBI59	AU 10U" MIN OVER 50~120U" NI
2	Barrel	1	HBI59	AU 10U" MIN OVER 50~120U" NI
3	Spring	1	SUS 304	N/A
4	Plug	1	HBI59	AU 10U" MIN OVER 50~120 U" Ni

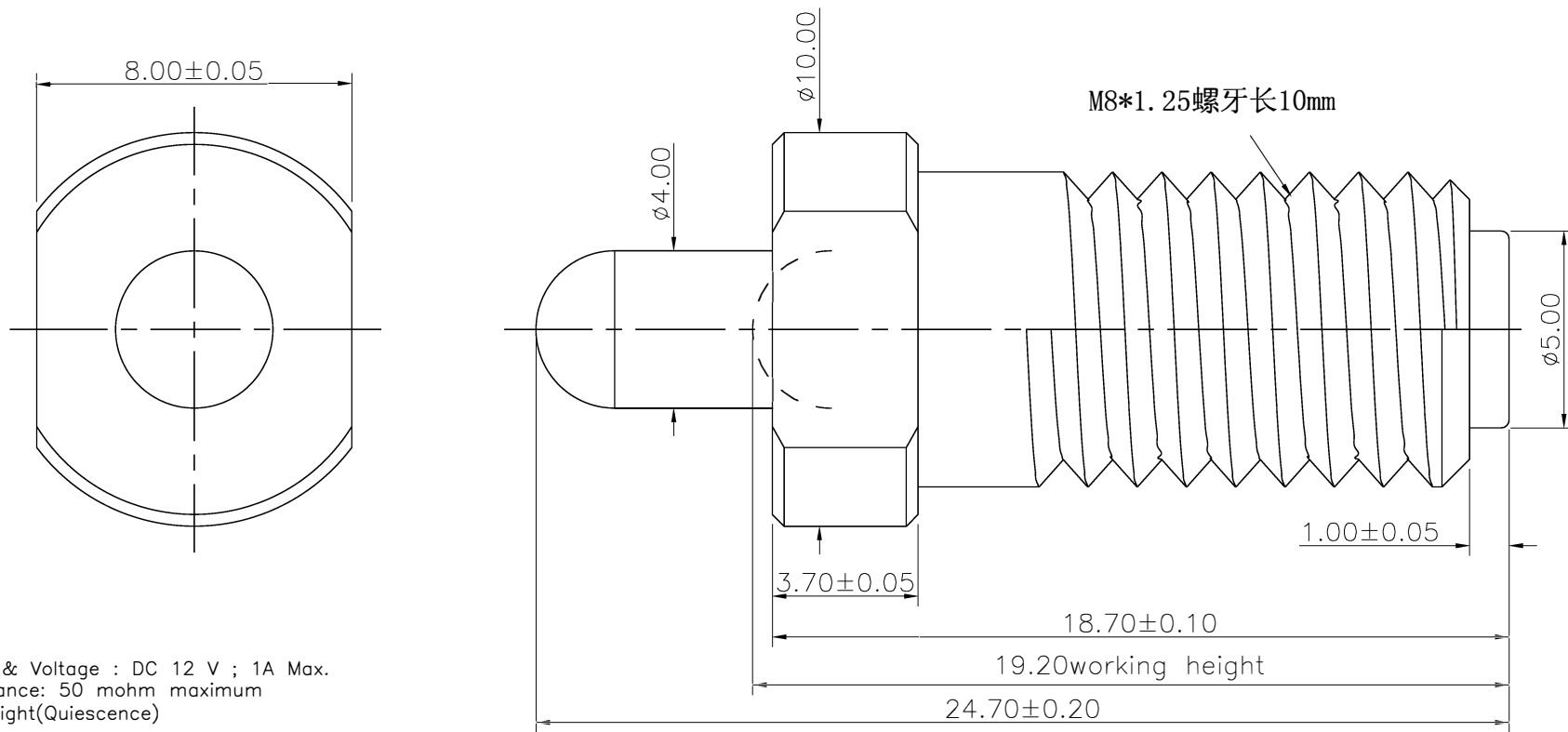

NOTES:

- Electrical
 - .Rated Current & Voltage : DC 12 V ; 1A Max.
 - .Contact Resistance: 50 mohm maximum at Working Height(Quiescence)
- Mechanical
 - .Full store: 6.00 mm
 - .Working Store: 5.50 mm
 - .Spring Force: 1800gf±200gf at Working Height
 - .Durability:100,000 cycles(minimum)
- Environmental
 - .Operating Temperature: -40°C~+85°C
 - .Humidity Range: 10%RH~90%RH
 - .Salt Spray: 96 Hours
- When the current is greater than 1A then need to increase the time delay circuit(3 second)
- To avoid arcing issue, The adaptor start to power supply after connector mated fully.
- To ensure the best usage, please operate it based on the working height.
- .RoHs&HF compliant product.

CUSTOMER NO.		1.40.0498			东莞市双盟电子有限公司	
DRAWN	lys	DATE	2021.12.20			
CHECKED		SCALE	10:1	VER. A.0		
APPROVED		TITLE	M8螺纹弹簧针2		Ang:	Dim:
PROJECT		DRAWING NO.	PPM.01-248-1002		0 ±1°	0 ±0.15
SHEET	1 of 1	UNIT	mm		.0 ±0.5°	.0 ±0.10
					.00 ±0.25°	.00 ±0.05

VER.	DESCRIPTION	ECN NO.	DATE