

Please Approve this Drawing	
Date	
Signature	

NO.	Part Name	Q'TY	Material	Plated surface
1	Plunger	1	无铅铜	Au 1u" Min. OVER 50~120 U" NI
2	Barrel	1	无铅铜	Au 1u" Min. OVER 50~120 U" NI
3	Spring	1	SUS 304	/
4				
5				

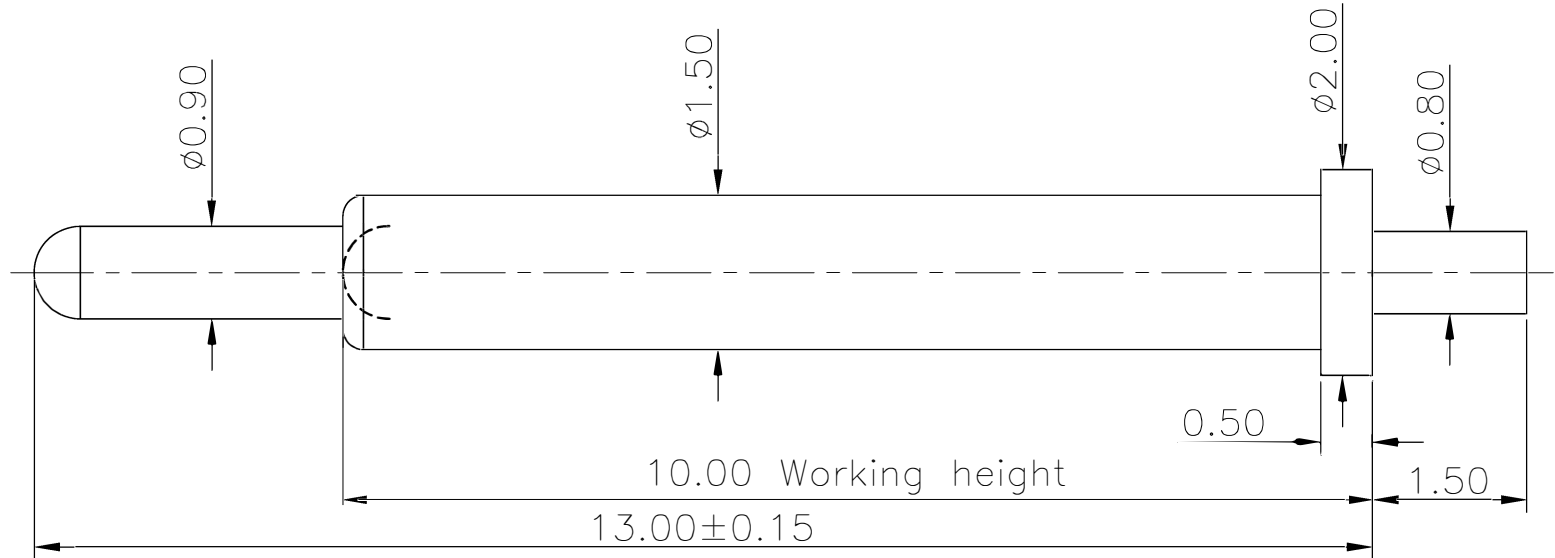

NOTES:

- Electrical
  - .Rated Current & Voltage : DC 12 V ; 1.0A Max.
  - .Contact Resistance: 50 mohm maximum at Working Height(Quiescence)
- Mechanical
  - .Full store: 3.00 mm
  - .Spring Force: 130gf±20%gf at Working Height
  - .Durability:10,000 cycles(minimum)
- Environmental
  - .Operating Temperature: -40°C~+85°C
  - .Humidity Range: 10%RH~90%RH
- When the current is greater than 1A then need to increase the time delay circuit(3 second)
- To avoid arcing issue, The adaptor start to power supply after connector mated fully.
- To ensure the best usage,please operate it based on the working height.
- .RoHs&HF compliant product.

VER.	DESCRIPTION	ECN NO.	DATE

DRAWN	lys	DATE	2021.07.15			东莞市双盟电子有限公司	
CHECKED		SCALE	10:1	VER.	A.0		
APPROVED		TITLE	pogo pin			Ang:	Dim:
PROJECT		DRAWING NO.	PPM.01-577-0102			0 ±1°	0 ±0.15
SHEET	1 of 1	UNIT	mm			.0 ±0.5°	.0 ±0.10
						.00 ±0.25°	.00 ±0.05