

Note:

...Materials:

Plunger: Brass C3602 ,plating 3U" Min Au over 60~100U" Ni .
 Barrel: Brass C3602 ,plating 3U" Min Au over 60U" ~100Ni" .
 Spring: sus304 .

...Mechanical:

Spring force: 50g±20g, at 0.7mm working storke.
 Full storke: 1.00mm.
 Mechanical life: 50000 cycle Min.

...Electrical:

Voltage: 12.0 V.
 Current: 1.0A .
 Contact resistance: 50mΩ Max at working height.

...ROHS or REACH compliant product.

...Salt spray test: 48 H.

...& Key inspection dimension .

To ensure the best usage

please operate it based on the working height.

Based on the engineering drawings,

shall not exceed the maximum allowed compression.

REV	Description	ECN NO	DATE
TO		—	2021/10/11

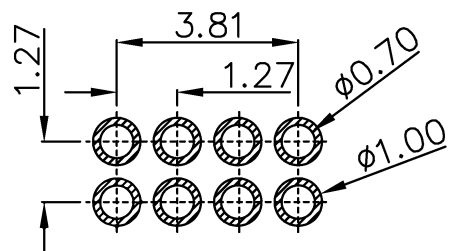
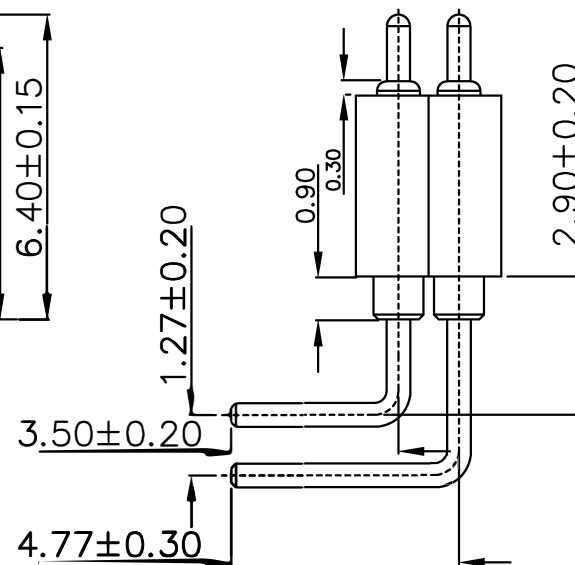
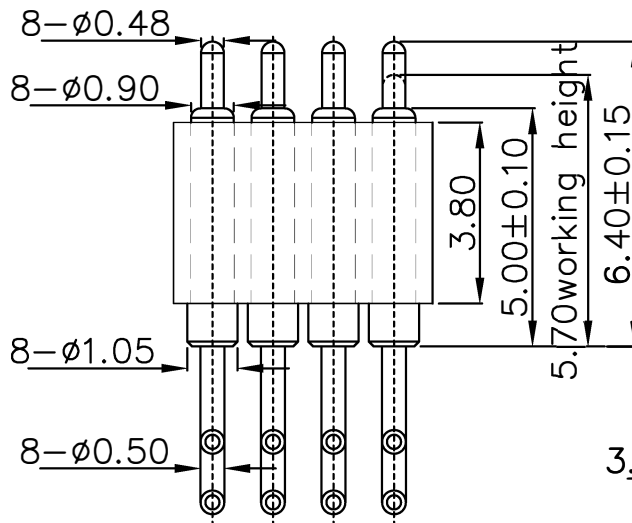
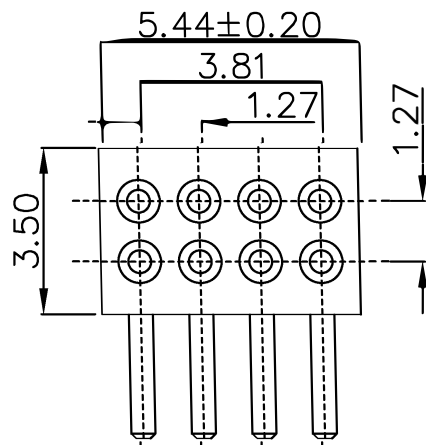

Recommended pcb layout
 Layout tolerance: ±0.05mm

东莞市双盟电子有限公司

Nuits: mm	Tolerance	Drawn:
Scale: 1:1	0~6 ±0.05	Checked:
Size: A4	7~50 ±0.10	Approved:
Title:	Sheet: 1/1	>50 ±0.20
Part NO:	Porj:	Angle: ±2°

Title: 8pin connector
 Part NO: PPM.08-949-0303

Other tolerance unless otherwise noted
 (其他公差除非另有说明)