

Note:

... Materials:

Plunger: **Brass** C3604 ,plating 3U" Min Au over 60~100U" Ni min;

Barrel: **Brass** C3604 ,plating 3U" Min Au over 60~100U" Ni min;

Spring: SUS304 ;

Housing: Black HTN30%GF UL94 V-0;

A ... Mechanical:

Spring force: 40g±15g, at 1.0mm working height.

Full storke: 1.4mm.

Mechanical life: 20000 cycle Min.

... Electrical:

Voltage: 12 V.

Current: 2A Max.

Contact resistance: 50mΩ Max at working height.

... ROHS or REACH compliant product.

... Salt spray test: 48 H.

... & Key inspection dimension .

To ensure the best usage, please operate it based on the working height.

B Based on the engineering drawings, shall not exceed the maximum allowed compression.

REV	Description	ECN NO	DATE
T0	—	—	2020/6/20

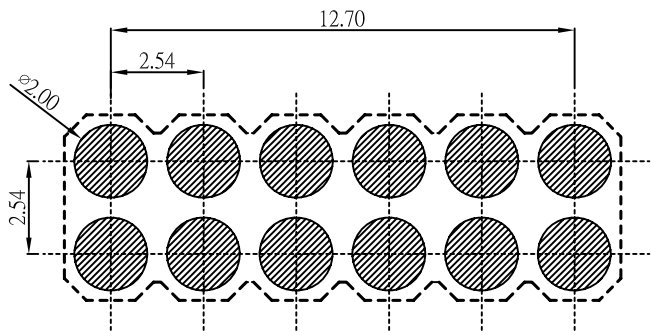
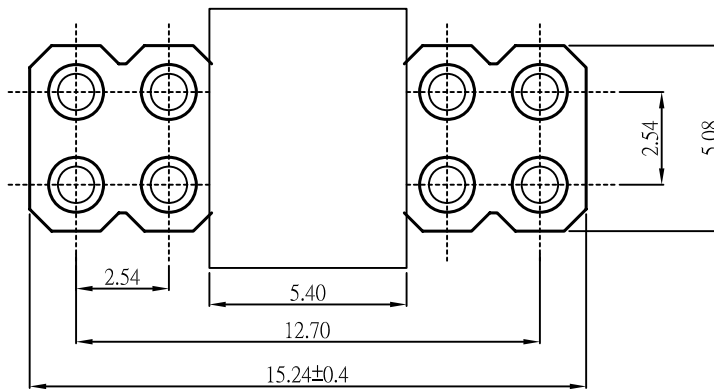

Recomended pcd layout  
layongt tolerance: ±0.05mm

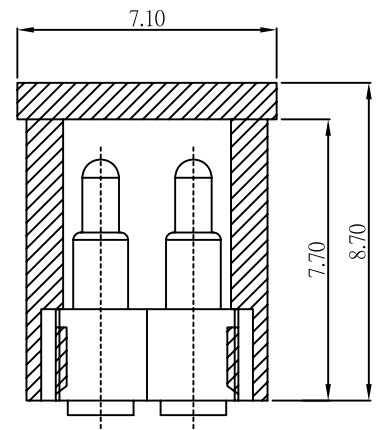
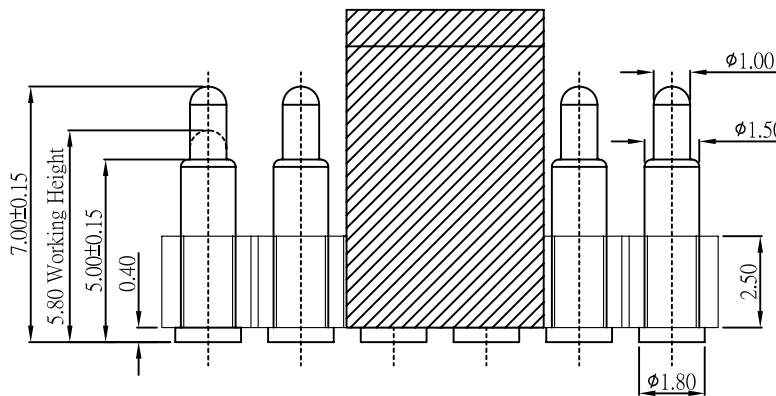

D 东莞市双盟电子有限公司

Nuits:	mm	Tolerance	Drawn:	
Scale:	1:1	0~6 ±0.05	Checked:	
Size:	A4	7~50 ±0.10	Approved:	
Title:	12pin connector	Sheet: 1/1 >50 ±0.20	Other tolerance unless otherwise noted (其他公差除非另有说明)	
Part NO:	PPM.12-593-0302	Porj:	Angle: ±2°	