

Please Approve this Drawing

Date

Signature

NO.	Part Name	Q'TY	Material	Plated surface
1	Plunger	4	HBi59	Au 5u" Min. Over 50u" Min. Ni
2	Barrel	4	HBi59	Au 3u" Min. Over 50u" Min. Ni
3	Spring	4	SUS304	
3	Ball	4	SUS304	Au 1u" Min. Over 50u" Min. Ni
4	Housing	1	High temp.Plastic; UL94 V-0 Color Black	
5	Magnet	2	NdFeB	Plating Ni

- NOTES:
- Electrical
    - .Rated Current & Voltage : DC 12 V ; 3.0A Max.
    - .Contact Resistance: 50 mohm maximum at Working Height(Quiescence)
  - Mechanical
    - .Full store: 0.70 mm
    - .Working Store: 0.50 mm
    - .Spring Force: 40gf±10gf at Working Height
    - .Durability:10,000 cycles(minimum)
  - Environmental
    - .Operating Temperature: -25°C~+85°C
    - .Humidity Range: 10%RH~90%RH
    - .Salt Spray: 48 Hours
  - When the current is greater than 1A then need to increase the time delay circuit(3 second)
  - To avoid arcing issue, The adaptor start to power supply after connector mated fully.
  - To ensure the best usage,please operate it based on the working height.
  - .RoHs&HF compliant product.

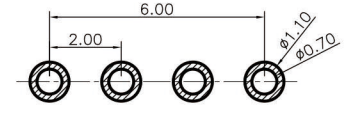
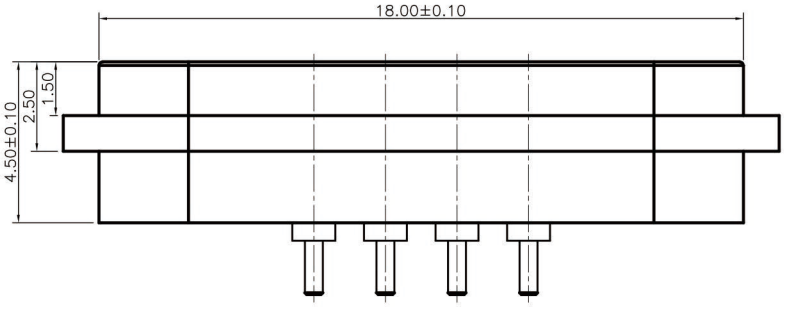
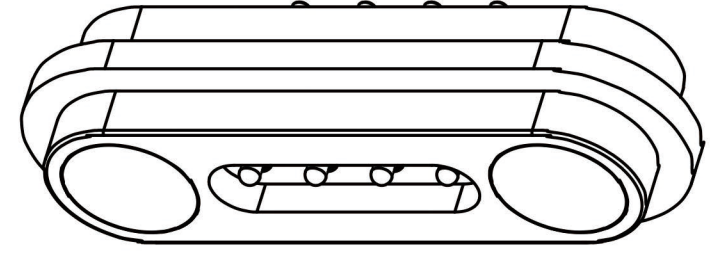
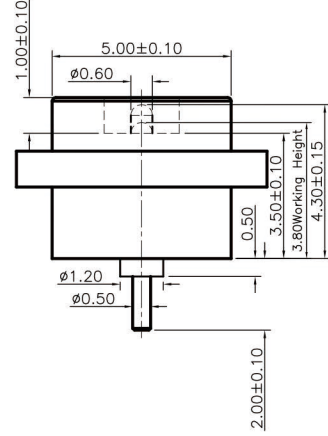
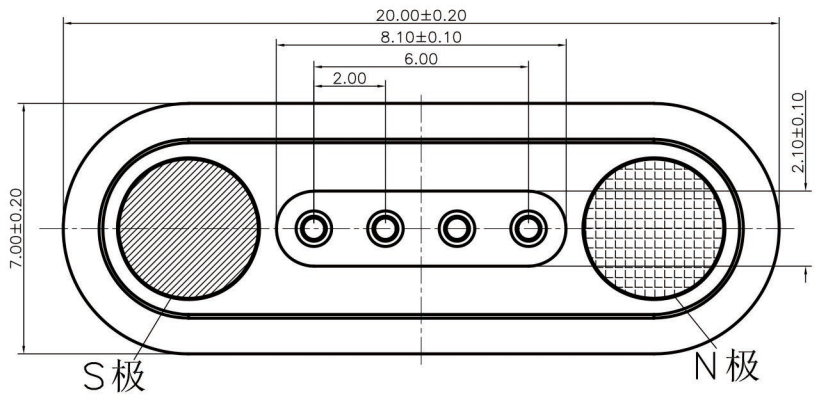

Recommended pcb layout  
Layout tolerance: ±0.05mm

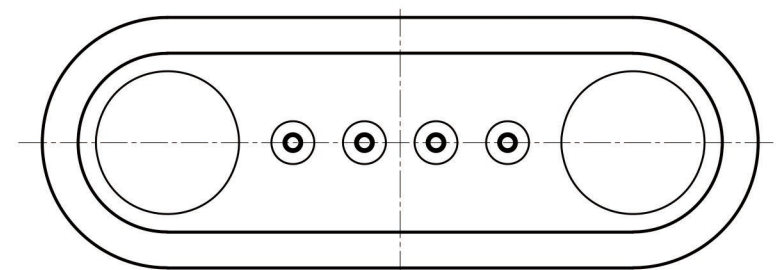

DRAWN	CDH	DATE	2022.07.22	东莞市双盟电子有限公司	
CHECKED		SCALE	10:1	VER.	B.0
APPROVED		TITLE	pogo pin male connector.		Ang:
PROJECT		DRAWING NO.	PPM.04-808-0502	0 ±1°	0 ±0.20
SHEET	1 of 1	UNIT	mm	.0 ±0.5°	.0 ±0.15
				.00 ±0.25°	.00 ±0.10

VER.	DESCRIPTION	ECN NO.	DATE
------	-------------	---------	------

Please Approve this Drawing

Date

Signature

NO.	Part Name	Q'TY	Material	Plated surface
1	Pin	4	HBi59	Au 5u" Min. OVER 50U~120" Ni
2	Magnet	2	NdFeB	Ni Plating
3	Housing	1	High temp.Plastic; UL94 V-0 Color Black	

- NOTES:
- Electrical
    - .Rated Current & Voltage : DC 12 V ; 3.0A Max.
    - .Contact Resistance: 50 mohm maximum at Working Height(Quiescence)
  - Environmental
    - .Operating Temperature: -40°C~+85°C
    - .Humidity Range: 10%RH~90%RH
    - .Salt Spray: 48 Hours
  - .RoHs&HF compliant product.

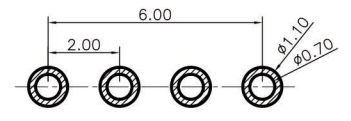
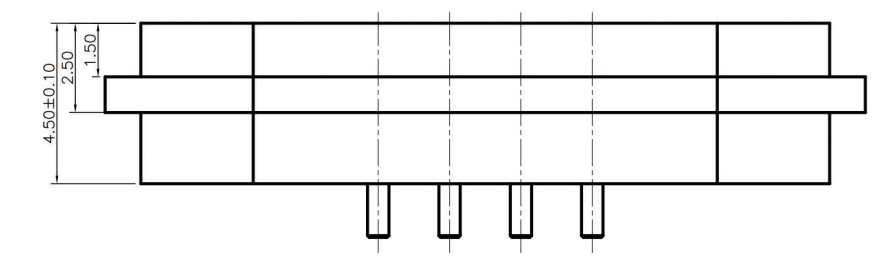
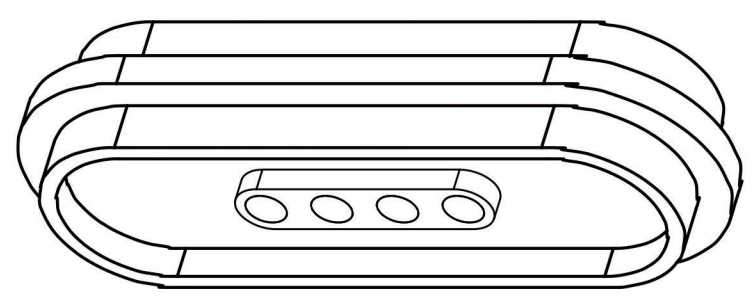
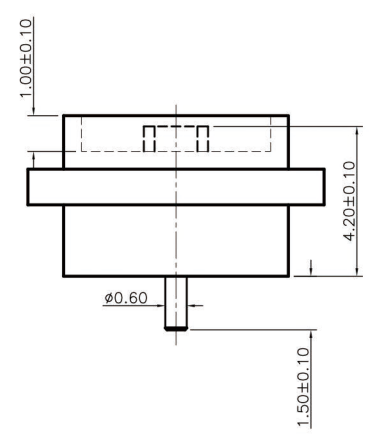
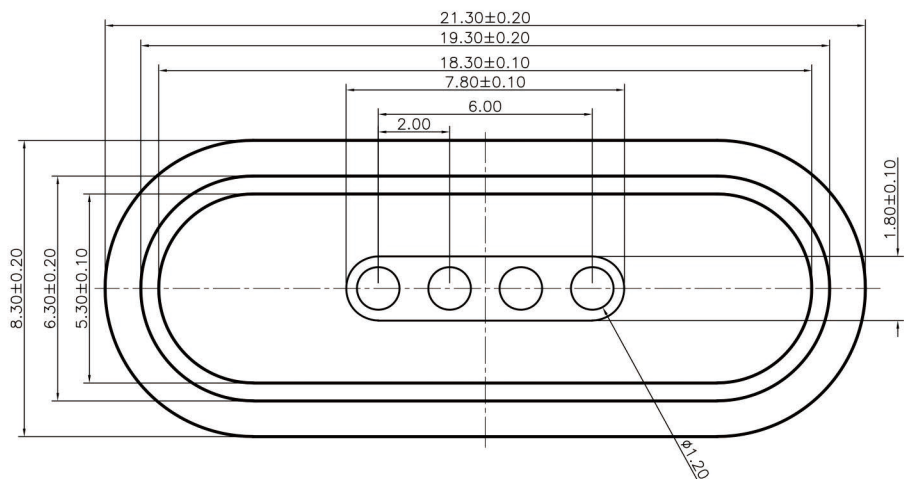

Recommended pcb layout  
Layout tolerance: ±0.05mm

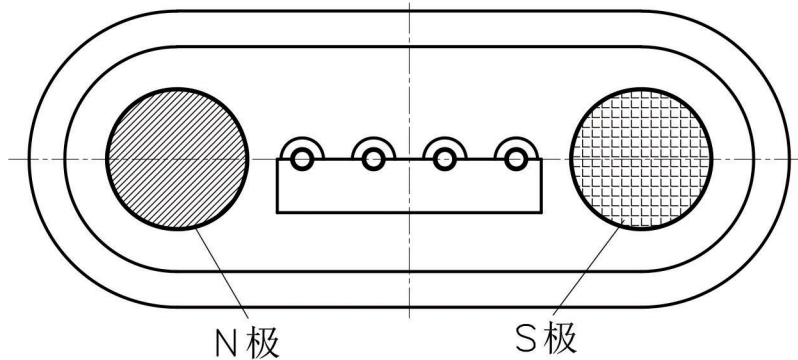

DRAWN	CDH	DATE	2022.07.22	东莞市双盟电子有限公司	
CHECKED		SCALE	10:1	VER.	B.0
APPROVED		TITLE	pogo pin female connector.		Ang:
PROJECT		DRAWING NO.	PPF.04-808-0502	0 ±1°	0 ±0.15
SHEET	1 of 1	UNIT	mm	.0 ±0.5°	.0 ±0.10
				.00 ±0.25°	.00 ±0.05

VER.	DESCRIPTION	ECN NO.	DATE
------	-------------	---------	------