

Please Approve this Drawing	
Date	
Signature	

NO.	Part Name	Q'TY	Material	Plated surface
1	Plunger	1	无铅铜 HBi59	AU 5 U" MIN OVER 50 U" MIN NI
2	Barrel	1	无铅铜 HBi59	Pt 20 U" MIN OVER 50 U" MIN NI
3	Spring	1	SUS 304	/

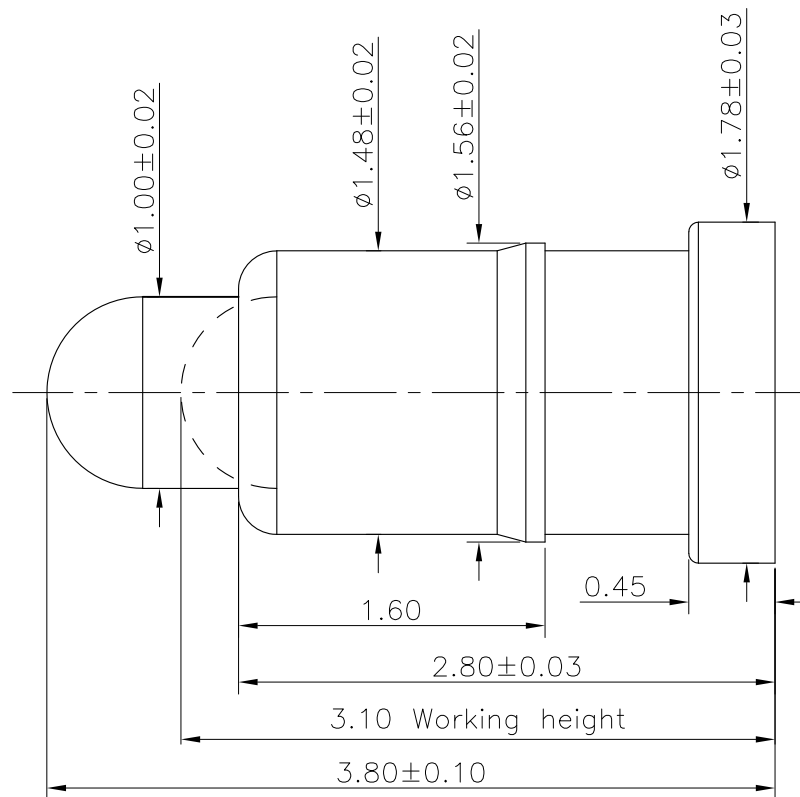

NOTES:

- Electrical
 - .Rated Current & Voltage : DC 12 V ; 1.0A Max.
 - .Contact Resistance: 100 mohm maximum at Working Height(Quiescence)
- Mechanical
 - .Full store: 1.00 mm
 - .Working Store: 0.70 mm
 - .Spring Force: 100gf \pm 20%gf at Working Height
 - .Durability:10,000 cycles(minimum)
- Environmental
 - .Operating Temperature: $-40^{\circ}\text{C} \sim +85^{\circ}\text{C}$
 - .Humidity Range: 10%RH \sim 90%RH
 - .Salt Spray: 48 Hours
- When the current is greater than 1A then need to increase the time delay circuit(3 second)
- To avoid arcing issue, The adaptor start to power supply after connector mated fully.
- To ensure the best usage, please operate it based on the working height.
- .RoHS&HF compliant product.
- 满足48小时盐雾要求, 500PPM氯水浸泡24小时Barrel不发黑;

DRAWN	CDH	DATE	2022.08.17			东莞市双盟电子有限公司
CHECKED		SCALE	10:1	VER.	A.0	
APPROVED		TITLE	PoGo Pin			Ang:
PROJECT		DRAWING NO.	PPM.01-5045-2002A			0 $\pm 1^{\circ}$
SHEET	1 of 1	UNIT	mm			.0 $\pm 0.5^{\circ}$
						.00 $\pm 0.25^{\circ}$
						Dim: 0 ± 0.15
						.0 ± 0.10
						.00 ± 0.05

VER.	DESCRIPTION	ECN NO.	DATE
------	-------------	---------	------