

| NO. | Part Name | VER | Q'TY | Material  | Plated surface                |
|-----|-----------|-----|------|-----------|-------------------------------|
| 1   | Plunger   | A.0 | 1    | HBI59     | AU 30U" MIN OVER 50~120 U" NI |
| 2   | Barrel    | A.0 | 1    | HBI59     | AU 15U" MIN OVER 50~120 U" NI |
| 3   | Ball      | A.0 | 1    | Zirconium |                               |
| 4   | Spring    | A.0 | 1    | SUS304    |                               |

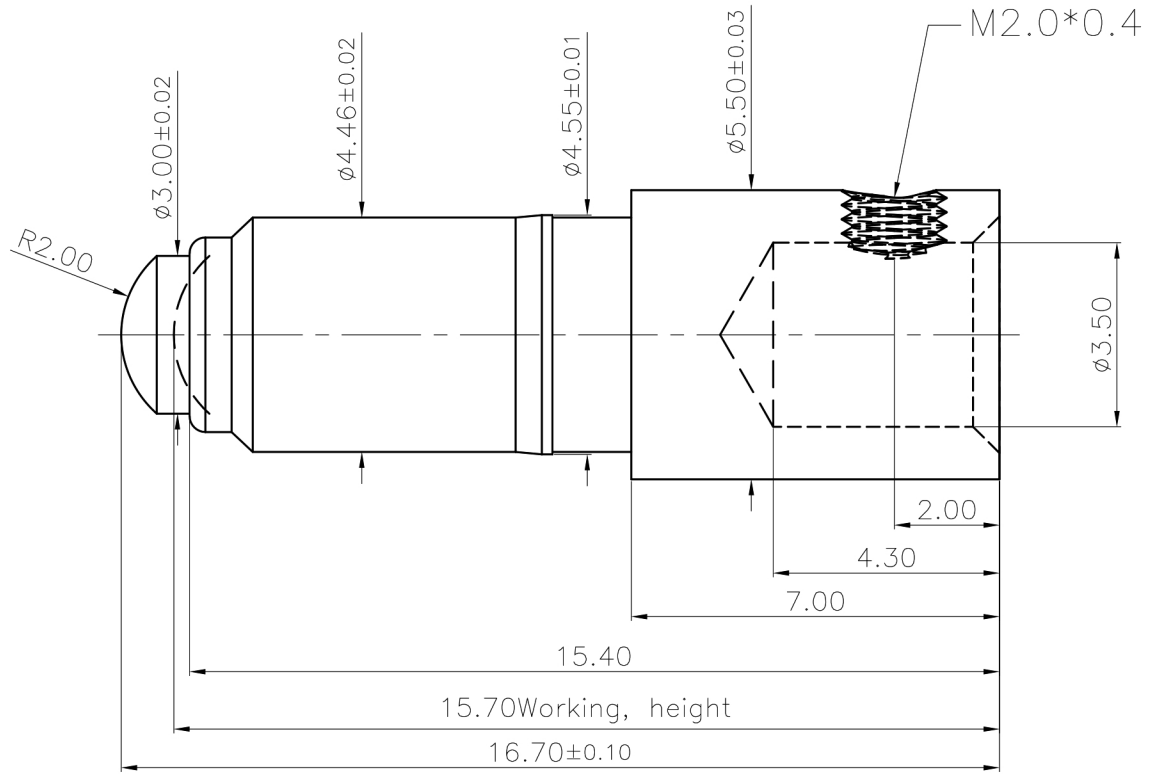

NOTES:

- Electrical
  - .Rated Current & Voltage : DC 28V ; 30A MAX.
  - .Contact Resistance: 50 mohm maximum at Working Height(Quiescence)
- Mechanical
  - .Spring Force: 200gf±20%gf at Working Height
  - .Durability:10,000 cycles(minimum)
- Environmental
  - .Operating Temperature: -25°C~+85°C
  - .Humidity Range: 10%RH~90%RH
  - .Salt Spray: 48 Hours
- When the current is greater than 1A then need to increase the time delay circuit(3 second)
- To avoid arcing issue, The adaptor start to power supply after connector mated fully.
- To ensure the best usage,please operate it based on the working height.
- .RoHS&HF compliant product.

|          |        |             |                  |      |     |             |           |
|----------|--------|-------------|------------------|------|-----|-------------|-----------|
| DRAWN    | CDH    | DATE        | 2023.03.10       |      |     | 东莞市双盟电子有限公司 |           |
| CHECKED  |        | SCALE       | 10:1             | VER. | A.0 |             |           |
| APPROVED |        | TITLE       | Pogo PIN         |      |     | Ang:        | Dim:      |
| PROJECT  |        | DRAWING NO. | PPM.01-5755-3002 |      |     | 0 ±1°       | 0 ±0.15   |
| SHEET    | 1 of 1 | UNIT        | mm               |      |     | .0 ±0.5°    | .0 ±0.10  |
|          |        |             |                  |      |     | .00 ±0.25°  | .00 ±0.05 |

| VER. | DESCRIPTION | ECN NO. | DATE |
|------|-------------|---------|------|
|      |             |         |      |

| (序号) | (部件名称)    | (数量) | (材 质)    | (表面处理)                        |
|------|-----------|------|----------|-------------------------------|
| NO.  | Part Name | Q'TY | Material | Plated surface                |
| 1    | Pin       | 1    | HBI59    | Au 30U" MIN OVER 50~150 u" Ni |

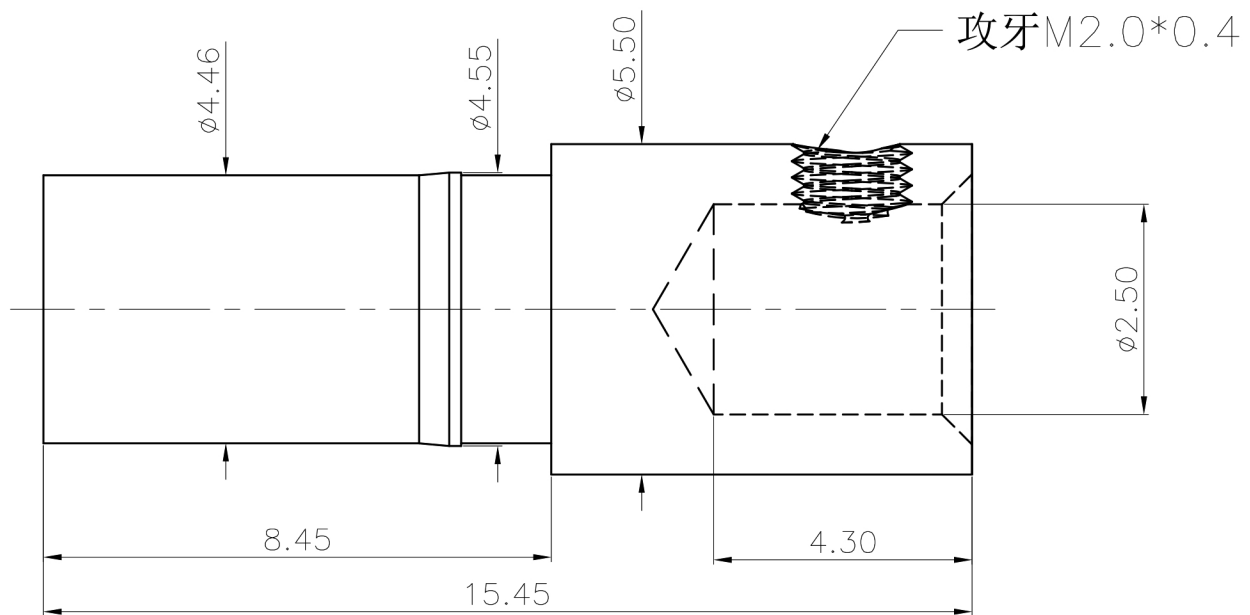

技术要求:

- 表面不得有毛刺,刮伤等不良.
- 表面粗糙度Ra0.4
- 标示\*为重点管控尺寸,制程管控.

|          |        |             |                  |      |     |             |           |
|----------|--------|-------------|------------------|------|-----|-------------|-----------|
| DRAWN    | CDH    | DATE        | 2023.03.10       |      |     | 东莞市双盟电子有限公司 |           |
| CHECKED  |        | SCALE       | 10:1             | VER. | A.0 |             |           |
| APPROVED |        | TITLE       | PIN              |      |     | Ang:        | Dim:      |
| PROJECT  |        | DRAWING NO. | PPF.01-5755-3002 |      |     | 0 ±1°       | 0 ±0.15   |
| SHEET    | 1 of 1 | UNIT        | mm               |      |     | .0 ±0.5°    | .0 ±0.10  |
|          |        |             |                  |      |     | .00 ±0.25°  | .00 ±0.05 |

| VER. | DESCRIPTION | ECN NO. | DATE |
|------|-------------|---------|------|
|      |             |         |      |