

Please Approve this Drawing	
Date	
Signature	

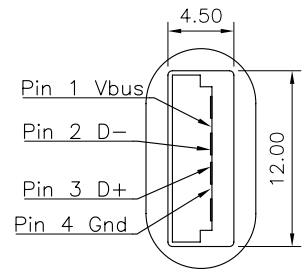

- NOTES:
- Electrical
 - .Rated Current & Voltage : DC 12 V ; 2A
 - .Contact Resistance:50 mohm maximum at Working Height(Quiescence)
 - .Insulation Resistance: 500MΩ Min. at 500VDC/Minute
 - .Dielectric Withstanding Voltage: At 500VAC/Minute No Breakdown
 - Mechanical
 - .Contact Retention Force:300gf/PIN Min.
 - Environmental
 - .Operating Temperature: -25°C~+85°C
 - .Humidity Range: 10%RH~90%RH
 - .Salt Spray: 48 Hours
 - Part To Be Free Form Manufacturing Lubricants.
 - RoHs&HF compliant product.
 - SMT Temperature: 265°C±5°, 2±0.5S
Soldering Temperature: 280°C±5°, 10±1S

Magnet Connector	USB 2.0	
	USB 2.0	Signal
1#	Pin 1	Vbus
2#	Pin 2	D-
3#(空PIN)	-	-
4#	Pin 3	D+
5#	Pin 4	Gnd

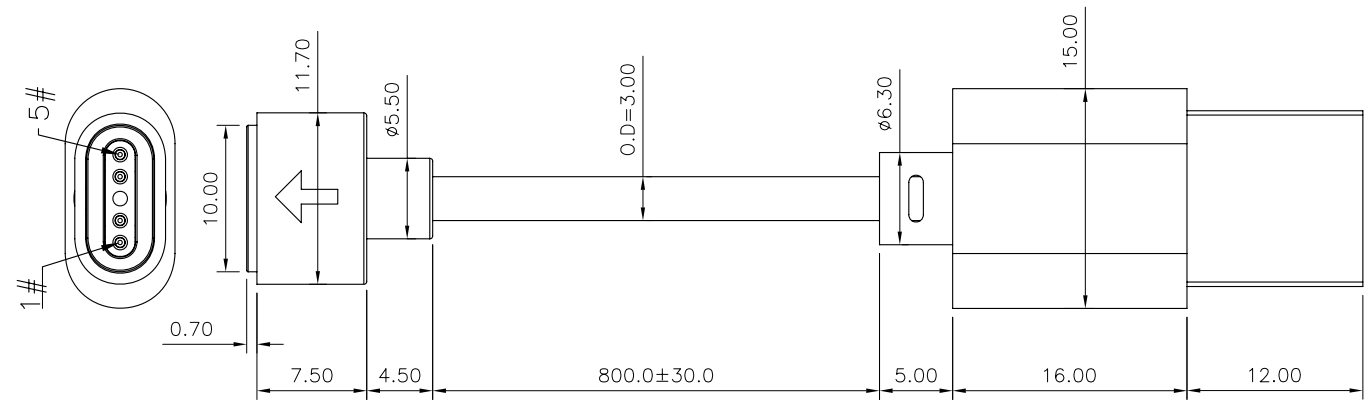
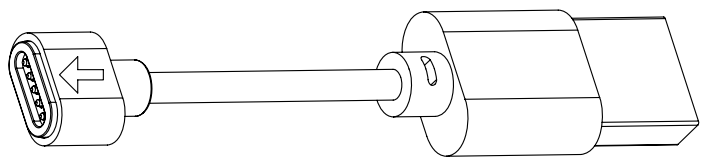

DRAWN	Roy.wei	DATE	2018.05.02			东莞市双盟电子有限公司		
CHECKED		SCALE	10:1	VER.	B.0			
APPROVED		TITLE	Magnet Connector To USB 2.0 Male			Ang:	Dim:	
PROJECT		DRAWING NO.	PCM.05-949-0101			0 ±5.0°	0 ±0.80	
SHEET	1 of 1	UNIT	mm			.0 ±3.0°	.0 ±0.50	
						.00 ±1.0°	.00 ±0.30	

VER.	DESCRIPTION	ECN NO.	DATE

Please Approve this Drawing

Date

Signature

NO.	Part Name	Q'TY	Material	Plated surface
1	Pin	5	C3604	AU 10 U" MIN OVER 50~100 U" NI
2	Housing	1	PA9T	UL 94V-0, Black
3	Magnet	1	N52	400~600u" Ni

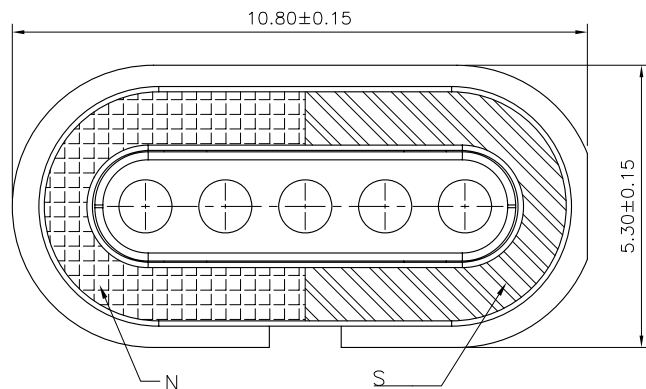

NOTES:

- Electrical
 - .Rated Current & Voltage : DC 12 V ; 1 A
 - .Contact Resistance: 30 mohm maximum at Working Height(Quiescence)
- Environmental
 - .Operating Temperature: -25°C~+85°C
 - .Humidity Range: 10%RH~90%RH
 - .Salt Spray: 48 Hours
- .RoHs&HF compliant product.

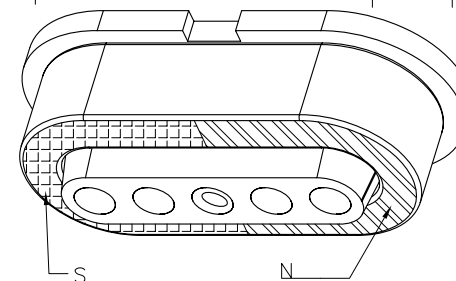
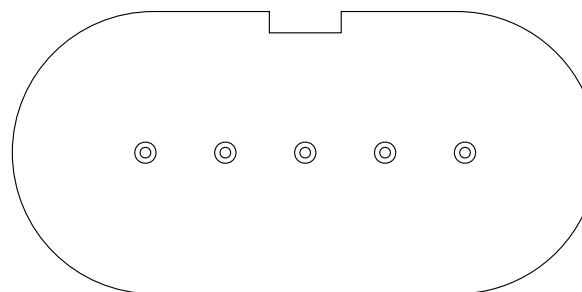
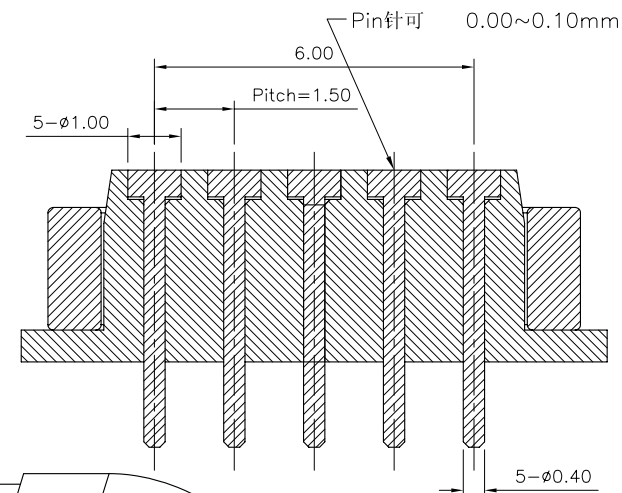
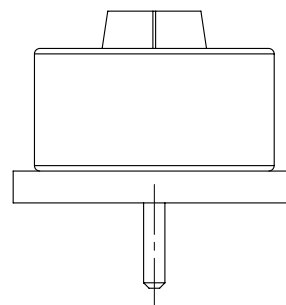
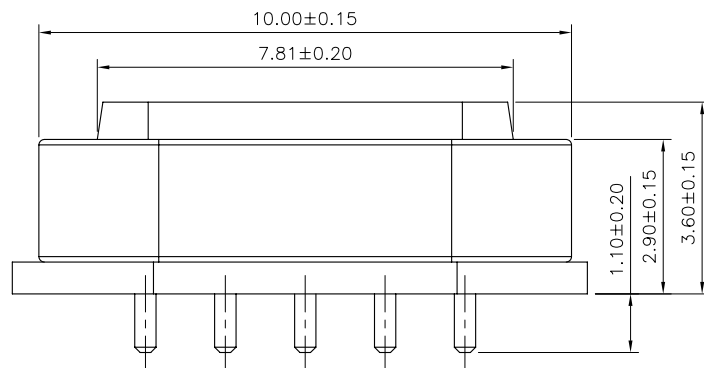
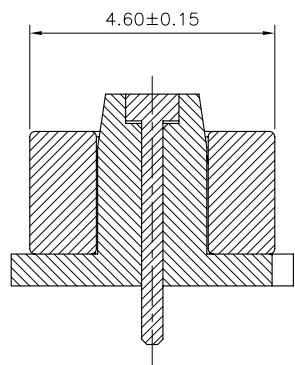

H719-05B
F719-0110A

胶芯削台阶后组装磁铁

DRAWN	Roy	DATE	2018.07.05		东莞市双盟电子有限公司	
CHECKED		SCALE	10:1	VER. B.0		
APPROVED		TITLE	pogo pin connector.		Ang:	Dim:
PROJECT		DRAWING NO.	PPF.05-719-1001		0 ±1°	0 ±0.15
SHEET	1 of 1	UNIT	mm		.0 ±0.5°	.0 ±0.10
					.00 ±0.25°	.00 ±0.05

VER.	DESCRIPTION	ECN NO.	DATE