

NO.	Part Name	VER	Q'TY	Material	Plated surface
1	Plunger	A.0	1	HBI59	AU 30U" MIN OVER 50~120 U" NI
2	Barrel	A.0	1	HBI59	AU 15U" MIN OVER 50~120 U" NI
3	Ball	A.0	1	Zirconium	
4	Spring	A.0	1	SUS304	

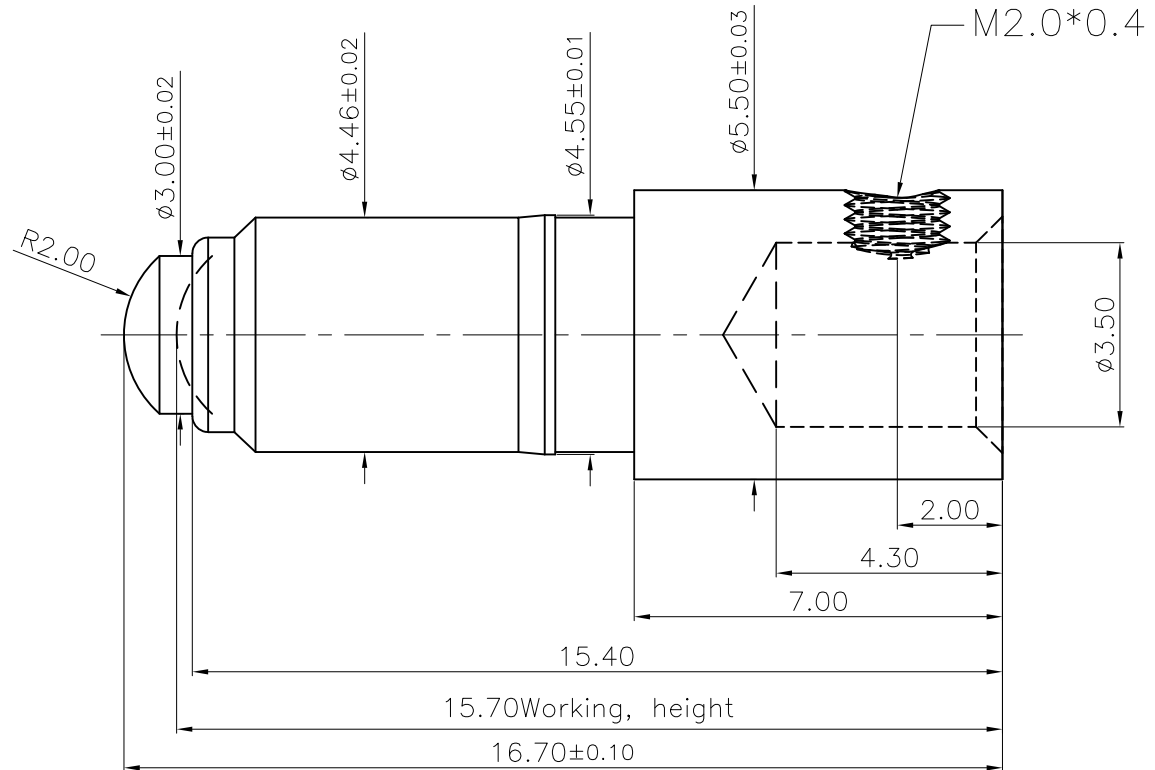

NOTES:

- Electrical
 - .Rated Current & Voltage : DC 28V ; 30A MAX.
 - .Contact Resistance: 50 mohm maximum at Working Height(Quiescence)
- Mechanical
 - .Spring Force: 200gf±20%gf at Working Height
 - .Durability:10,000 cycles(minimum)
- Environmental
 - .Operating Temperature: -25°C~+85°C
 - .Humidity Range: 10%RH~90%RH
 - .Salt Spray: 48 Hours
- When the current is greater than 1A then need to increase the time delay circuit(3 second)
- To avoid arcing issue, The adaptor start to power supply after connector mated fully.
- To ensure the best usage, please operate it based on the working height.
- .RoHS&HF compliant product.

DRAWN	CDH	DATE	2023.03.10			东莞市双盟电子有限公司			
CHECKED		SCALE	10:1	VER.	A.0				
APPROVED		TITLE	Pogo PIN			Ang:	Dim:		
PROJECT		DRAWING NO.	PPM.01-5755-3002			0 ±1°	0 ±0.15		
SHEET	1 of 1	UNIT	mm			.0 ±0.5°	.0 ±0.10		
						.00 ±0.25°	.00 ±0.05		

VER.	DESCRIPTION	ECN NO.	DATE