

1	2	3	4	5	6	7	8
LTR	REV	ECN NUMBER	DESCRIPTION	DATE	REVISED	APPROVE	
	XA		ORIGINAL RELEASE	2022/10/10	CYC	LI	

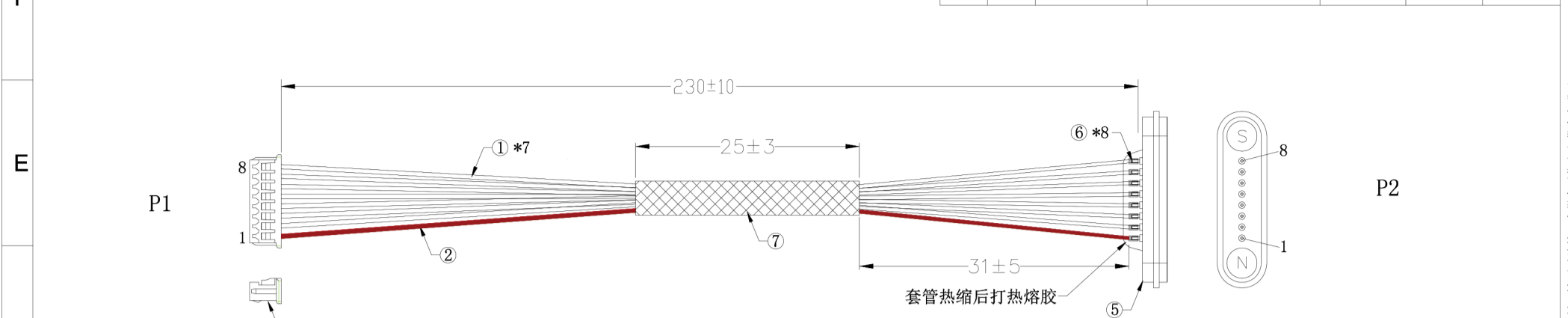

技术要求:
 1. 开路、短路、错位、瞬间开/短路必须100%测试
 2. 导通阻值: 5Ω MAX
 3. 绝缘阻抗: 5MΩ MIN
 4. 测试电压: DC 300V/0.01S
 5. 产品符合最新RoHS标准

NOTES:
 1. Electrical
 .Rated Current & Voltage : DC 12 V ; 3.0A Max.
 .Contact Resistance: 50 mohm maximum at Working Height(Quiescence)
 2. Mechanical
 .Full store: 0.70 mm
 .Working Store: 0.50 mm
 .Spring Force: 40gf±10gf at Working Height
 .Durability:10,000 cycles(minimum)
 3. Environmental
 .Operating Temperature: -25° C~+85° C
 .Humidity Range: 10%RH~90%RH
 .Salt Spray: 48 Hours
 4. Male and female docking magnetic force: 880kgf MIN.
 5. When the current is greater than 1A then need to increase the time delay circuit(3 second)
 6. To avoid arcing issue, The adaptor start to power supply after connector mated fully.
 7. To ensure the best usage, please operate it based on the working height.

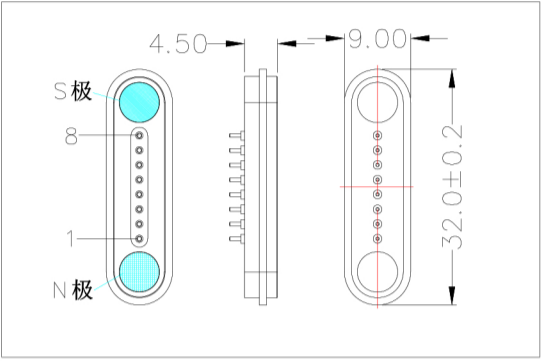

接点图

P1		P2
1	红	1
2	黑	2
3	黑	3
4	黑	4
5	黑	5
6	黑	6
7	黑	7
8	黑	8

7	套管	热缩柔性套管, 黑色, Ø5.0MM, L25mm	1	PCS										
6	套管	热缩柔性套管, 黑色, Ø1.5MM, L3.5mm	8	PCS										
5	pogo pin	8PIN公 POGO PIN +磁铁+黑色塑胶 (型号: PCM.08-856-0502)	1	PCS										
4	端子	PH1.25 端子 (Molex 型号: 500588100)	8	PCS										
3	HSG	PH1.25 8P HSG (Molex 型号: 510210800)	1	PCS	APPROVE									
2	线材	UL1571, 28# (7/0.127TS), 红色, PVC, OD=0.6MM, 无印字, RoHS+REACH	1	PCS	CHECK		.x ±	x. ° ±	GENERAL TOLERANCE		TITLE. Molex PH1.25 8P HSG TO POGO 8P L=230mm			
1	线材	UL1571, 28# (7/0.127TS), 黑色, PVC, OD=0.6MM, 无印字, RoHS+REACH	7	PCS	DRAW		.xx ±	.x ° ±			Product P/N. PCM.08-856-0502			
NO.	PART NO	ITEM	DESCRIPTION	Q' TY	UNIT	DATE	2022/10/10	.xxx ±				DWG NO. 1220	SHEET. 1/1	REV XA

PRODUCT DRAWING

1	2	3	4	5	6	7	8
LTR	REV	ECN NUMBER	DESCRIPTION	DATE	REVISED	APPROVE	
1	XA		ORIGINAL RELEASE	2022/8/18	CYC	LI	
2	XB		修改热缩套位置及长度	2022/10/10	CYC	LI	

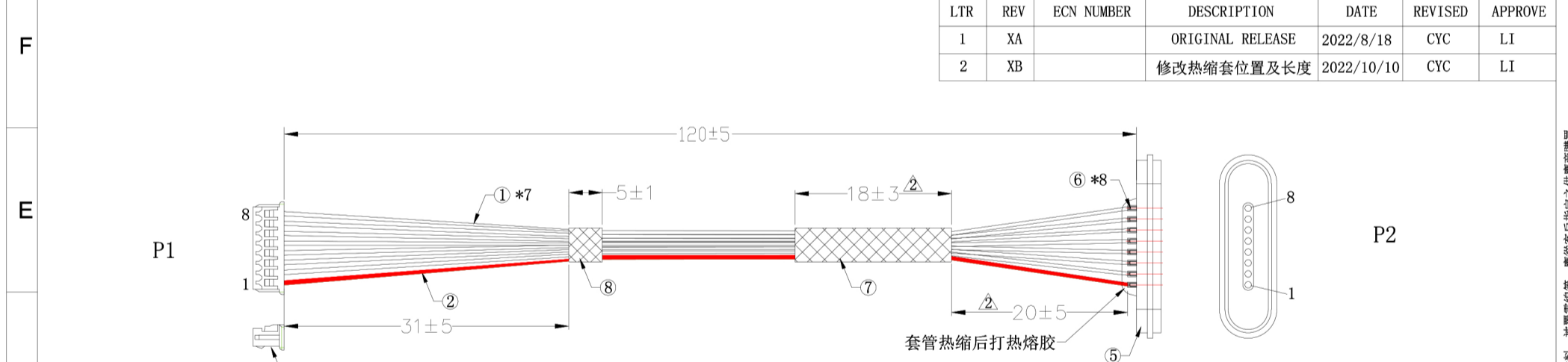

技术要求:
 1. 开路、短路、错位、瞬间开/短路必须100%测试
 2. 导通阻值: 5Ω MAX
 3. 绝缘阻抗: 5MΩ MIN
 4. 测试电压: DC 300V/0.01S
 5. 产品符合最新RoHS标准

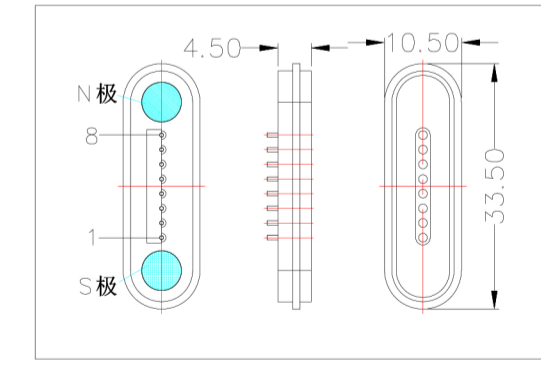

接点图

P1		P2
1	红	1
2	黑	2
3	黑	3
4	黑	4
5	黑	5
6	黑	6
7	黑	7
8	黑	8

8	套管	热缩柔性套管, 黑色, Ø5.0MM, L5mm	1	PCS										
7	套管	热缩柔性套管, 黑色, Ø5.0MM, L18mm	1	PCS										
6	套管	热缩柔性套管, 黑色, Ø1.5MM, L3.5mm	8	PCS										
5	pogo pin	8PIN母 POGO PIN +磁铁+黑色塑胶 (型号: PPF.08-856-0502)	1	PCS										
4	端子	PH1.25 端子 (Molex 型号: 500588100)	8	PCS										
3	HSG	PH1.25 8P HSG (Molex 型号: 510210800)	1	PCS	APPROVE									
2	线材	UL1571, 28# (7/0.127TS), 红色, PVC, OD=0.6MM, 无印字, RoHS+REACH	1	PCS	CHECK		.x ±	x. ° ±	GENERAL TOLERANCE		TITLE. Molex PH1.25 8P HSG TO POGO 8P母 L=120mm			
1	线材	UL1571, 28# (7/0.127TS), 黑色, PVC, OD=0.6MM, 无印字, RoHS+REACH	7	PCS	DRAW		.xx ±	.x ° ±			Product P/N. PCF.08-856-0502			
NO.	PART NO	ITEM	DESCRIPTION	Q' TY	UNIT	DATE	2022/10/10	.xxx ±				DWG NO. 1121	SHEET. 1/1	REV XB

PRODUCT DRAWING

本公司所有產品均為HSF產品, 選材時不可使用《有害物質管理標準》內限用之物料。對客戶特殊制定之原材料, 如成型樹脂、油墨、塗料、被覆電線等, 應從客戶指定之供應商購買。